



INSTRUCTIONS

45-1202

CHROME ABS ROTORS COVERS

FOR GL1800

Note: Read thoroughly before installing.

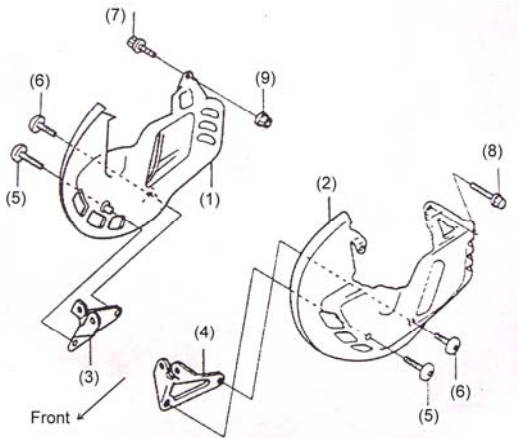

Parts List

No	Description	Qty
1	Right Front Disc Cover	1
2	Left Front Disc Cover	1
3	Right Stay	1
4	Left Stay	1
5	6 mm Socket Bolt (Long)	2
6	6 mm Socket Bolt (Short)	2
7	6 mm SH Flange Bolt (Short)	1
8	6 mm SH Flange Bolt (Long)	1
9	6 mm Flange Nut	1

Tools Required

Socket (8 mm)
 Ratchet
 Box-end Wrench (10 mm)
 Hex Wrench (5 mm)

Torque Chart

Be sure to tighten all bolts and nuts to their specified torques.

Item	N-m	kgf-m	lbf-ft
6mm SH Flange Bolt	9	.09	6.5
6mm Socket Bolt	10	1.0	7
6mm Flange Nut	12	1.2	9

Installation

1. Remove the front fender.

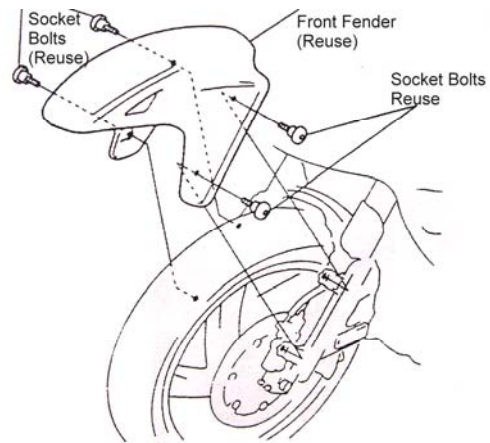

2. Remove the left front fender cover.

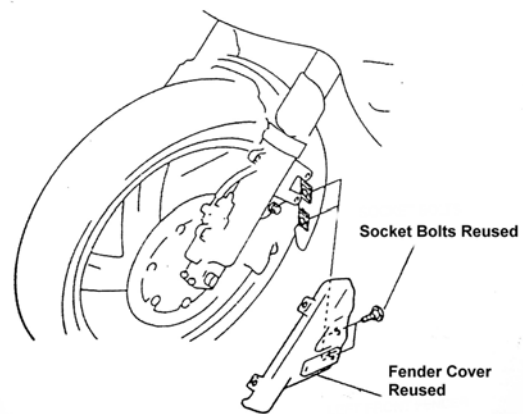

3. Remove the right front fender cover.

4. Remove the bolts.

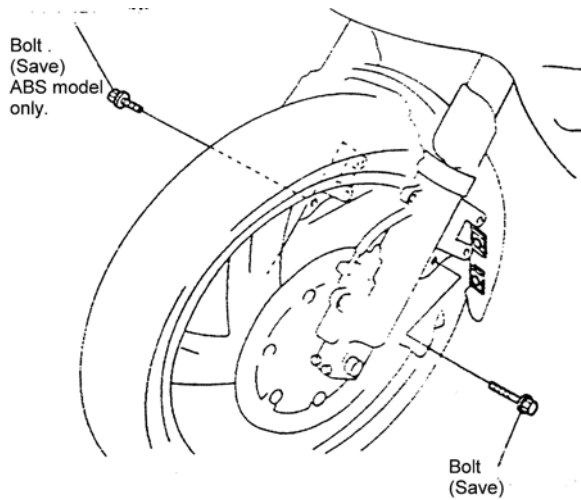

5. Install the left stay as shown.

6. Install the right stay in the same manner.

Note: Install the stays one by one.

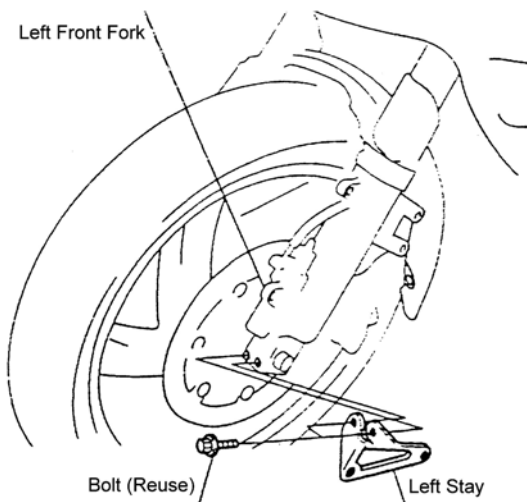

7. Temporarily install the left front disc.

8. Temporarily install the right front disc cover in the same manner.

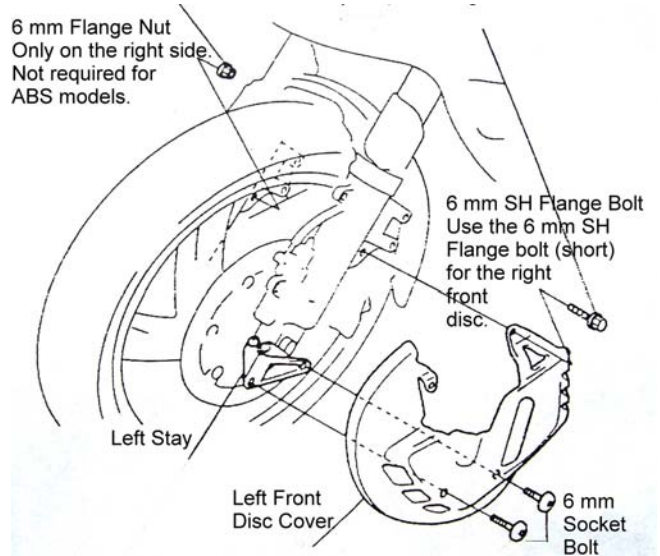

9. Reinstall the front fender and front fender covers in the reverse order of removal.

10. Tighten all bolts and nuts to the specified torques.